



Installation Guide

• Complete System

PREMIUM CLADDING COLLECTION

INSTALLATION GUIDE

COMPLETE SYSTEM

PREPARATION • PROFILES • PREPARATION & INSTALLATION • AFTER CARE



PREMIUM CLADDING COLLECTION

INSTALLATION GUIDE



Raising the bar, perfecting quality

Offering the complete hygienic cladding system that is strong, durable and long lasting even in the most extreme environments. Our wall cladding system can be used in hygienic and wet room environments. Offering a comprehensive range of high quality sheets, ceiling planks and profiles that are available in Brilliant White, Satin range (pastel colours) and Gloss range (vibrant colours).

We also offer an advanced professional collection of high performance adhesive and silicones with a range of unique benefits. This collection is appropriate for a wide range of environments, including general purpose and sanitary use.

Important Information Prior to Installation

It is essential to obtain a consistent appearance when installing hygienic wall cladding. Please adhere to these important guidelines:

- Ensure that the sheet production batch codes are consistent - NEVER install sheets with different batch codes.
- Ensure that the sheets are installed in the same orientation throughout. This guaranteeing that the grain of sheet is consistent. The protective film on the sheet should provide relevant guidance.
- Always store the sheets correctly. This will avoid warped sheets.

For any further questions please contact our technical department on:



www.oadbyplastics.co.uk



0116 232 1010



sales@oadbyplastics.co.uk

Please Note: This guide has been compiled to the best of our knowledge and is for guidance only. Oadby Plastics cannot be held responsible for any faults which may occur.





WATERPROOF

Suitable for all wet room and interior environments



FIRE RETARDANT

V-0 BS 476 Part 6
Class 1 BS 476 Part 7



EASY TO FABRICATE

Perfect for all fittings and installations



CHEMICAL RESISTANT

Perfect for chemical preparation environments



EXCEEDINGLY DURABLE

Enhancing material performance, service life and cost maintenance



LIGHTWEIGHT MATERIAL

Easy to handle and install for fittings and installations



PROTECTIVE FILM

Superior quality product protection, anti-fraud, branded protective film

CONTENTS

4 Preparation

P.4 | Surface Preparation
Suitable Substrates
Installation Temperatures
Recommended Tools and Equipment

P.5 | Recommended Safety Equipment
Safety Information
Workstation Preparation
Room Preparation

6 Profiles

P.6 | Profile Range Overview

P.7 | Profile Range Overview

P.8 | Installing Bottom Sheet Edge
Installing Ceiling and Top Sheet Edge

P.9 | Installing Joiner and Transition Profiles

10 Preparation & Installation

P.10 | Planning Layout
Sheet Preparation
Product Expansion

P.11 | Thermoforming

P.12 | Heat Welding

P.13 | Ceiling Installation

14 After Care

P.14 | Hygienic Wall Cladding Cleaning Guide

 Full technical specification data available

Surface Preparation

- All surfaces must be clean, dry and free from all contamination.
- Any imperfections in the substrate should be filled.
- All electrical switches, power points etc, should be in a first fix state where possible.
- All electrical equipment should only be moved or altered by a qualified electrician.
- All pipes, bolts, etc. that are fixed through the sheet should have a minimum of 3mm expansion gaps and be sealed with the suitable Oadby Plastics silicone.

Suitable Substrates

- Most flat, clean and secure surfaces are suitable. An adhesive test is recommended prior to installation.
- Painted surfaces are suitable. An adhesive test is recommended prior to installation.
- All plastered surfaces must be free from dust.

Installation Temperatures

Our hygienic wall cladding sheets are recommended to be installed at approximately the same room temperature at which the area will be used when commissioned, this prevents warping of the product.

- A minimum temperature of 14°C is recommended for all installation areas.
- Sheets must be stored flat in the room for approximately 24 hours prior to the installation.

Recommended Tools and Equipment

The below list of tools and equipment will allow for a more efficient installation process:

- Spirit level
- Laser level
- Tape measure
- Hacksaw
- Stanley knife
- Tenon saw
- Hammer
- Files (round and square)
- Rubber mallet
- Mixing paddle
- Chalk line
- Notch trowel
- Jig saw
- Hole cutting drill bit

Recommended Safety Equipment

- Goggles/safety glasses
- Protective gloves
- Face mask (nose/mouth protection)
- Hard hat
- Safety boots
- Hi-viz safety vest

Safety Information

- The safety information on adhesive packaging/technical data must be strictly adhered to.
- Safety eye wear must be worn when necessary to avoid injury.
- A working area must be clearly signposted for the health and safety of others.
- Ventilation within the work area is essential.
- Dispose of all waste sensibly and carefully.
- Keep the working area clean and tidy.

Workstation Preparation

- A workstation in close proximity to the installation area will be beneficial.
- A separate glue-station is advised, this keeps the installation method clean and efficient.
- It is essential to protect the overall area around the work and glue-stations. If an adhesive spillage occurs, the adhesive must be cleaned up immediately, if allowed to set removal can be extremely difficult.

Room Preparation

Prior to installation, ensure all corners, doors and windows are free from contamination. This is essential as this process prevents installation issues that could be easily avoided.

- Once room preparation is complete, a datum line must be installed with a laser level for optimum accuracy. The datum line height (from sub-floor) should be calculated to allow for the appropriate skirting height.
- Once all of the calculations have been formed, you will need to visualise and plan the installation layout. This minimises the number of profiles used in the system and makes the overall installation method more efficient.

Profile Range Overview

Joiner and Transition Profiles

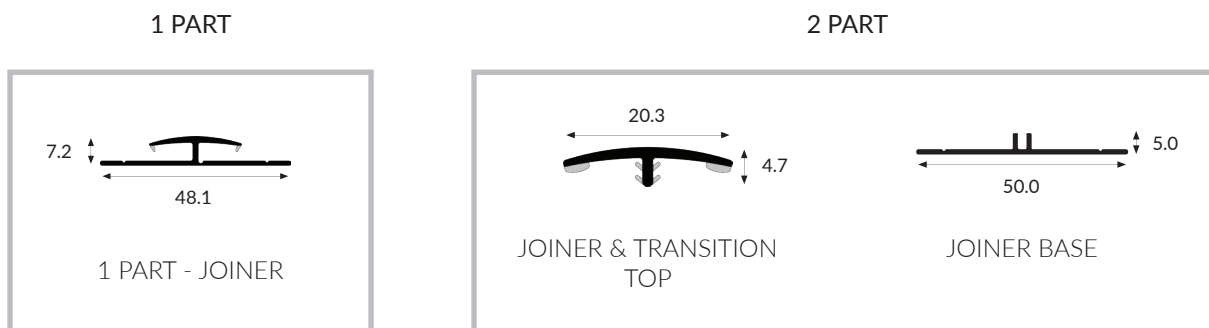

Joiner profiles are used to create a watertight seal between the sheet and the ceiling/flooring.

Capping and Transition Profiles

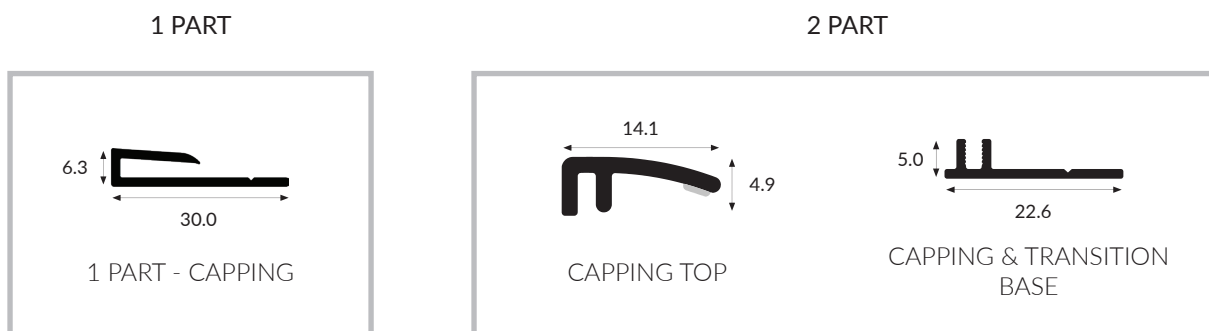

Capping profiles are used to create a watertight seal between the sheet and the ceiling/flooring.

Corner Profiles

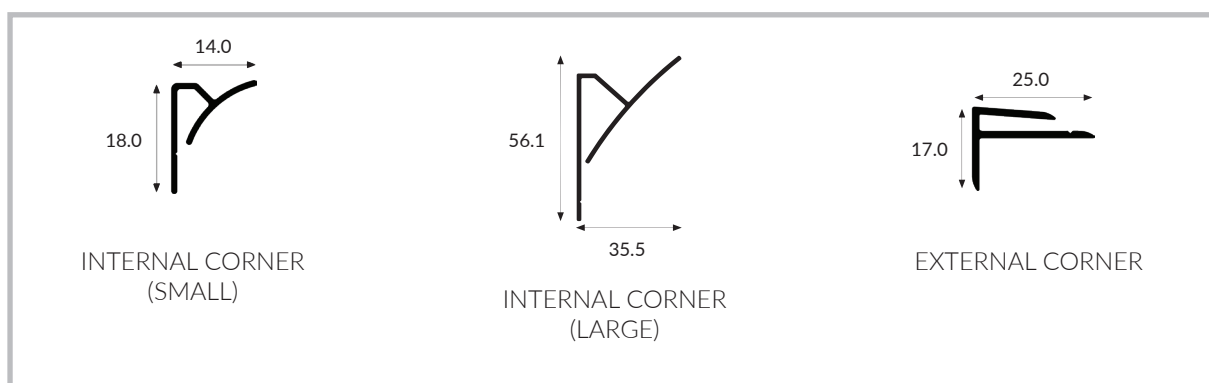

Corner profiles are used to create a watertight seal between two corner sheets.

Internal Angle Profiles

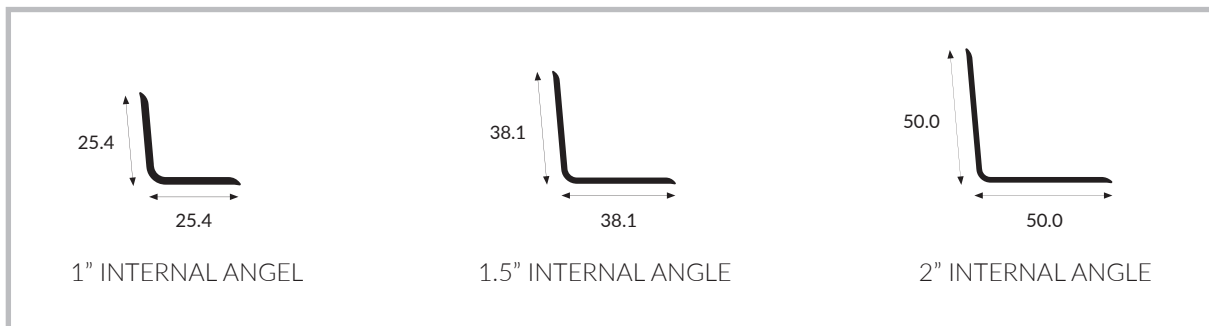

Internal angle profiles are used embedded corners to create a watertight corner seal.

Internal Angle Profiles

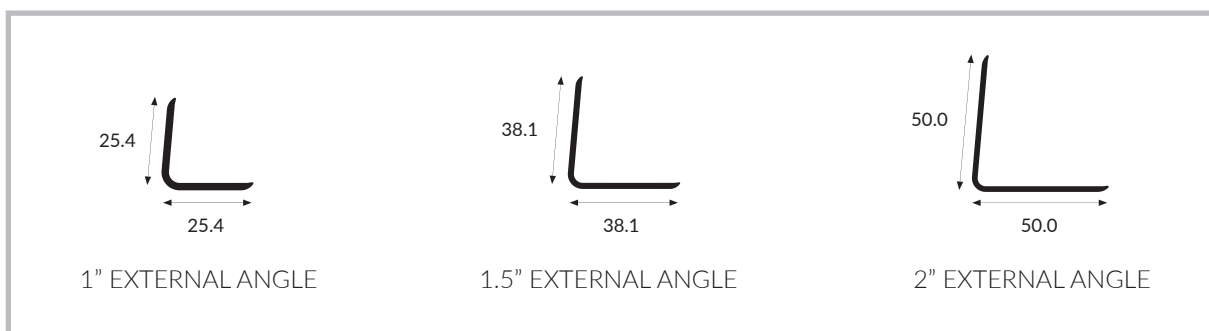

External angle profiles are used on extruded corners to create a watertight corner seal.

Ceiling Profiles

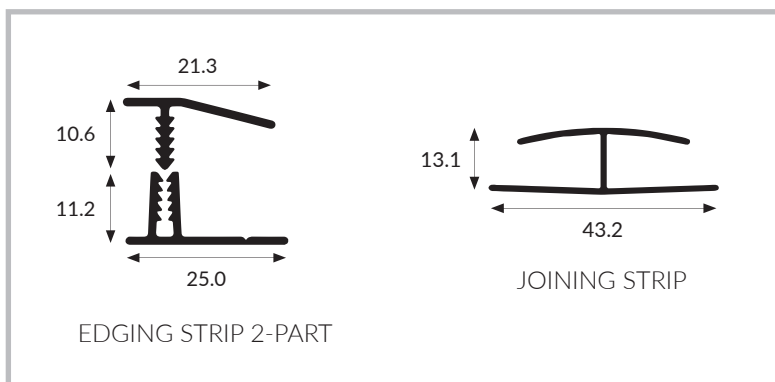

Ceiling profiles are used to create a strong, watertight seal for the ceiling planks to connect into.

Installing the Bottom of the Sheet

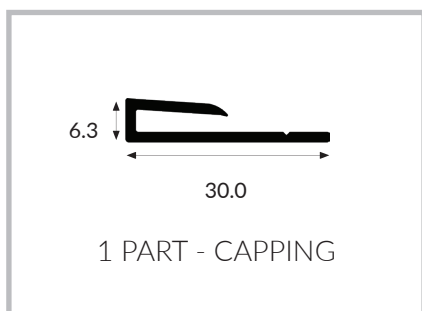

Step 1:

Connect the 1 Part - Capping profile to the wall with screws through the long edge of the profile. The use of silicone is especially important at the sheet base where wet cleaning may occur i.e. cleaning the floor.

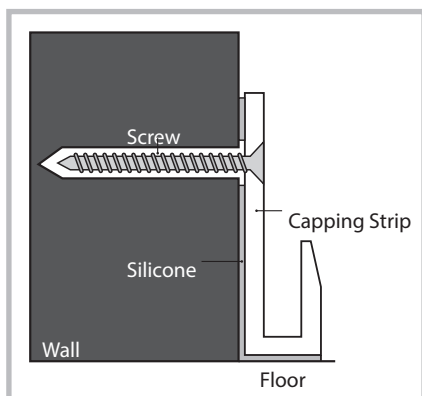

Step 2:

Additional silicone may be applied to the top and bottom edges of the profile to ensure a watertight seal is achieved.

Installing the Ceiling and Top of the Sheet

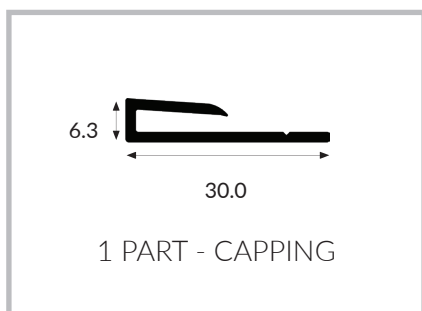

Step 3:

Connect the 1 Part - Capping profile to the top of the wall using the same principles in Step 1. When fitting the profile to the ceiling, you may prefer to trap the top of the sheet to the ceiling. Conclude with an Internal Corner profile as a coving. Ensure that you always leave room for expansion.

Please note:

When installing ceiling cladding, please consider the installation method prior to installing the top of the edge (please see page 13).

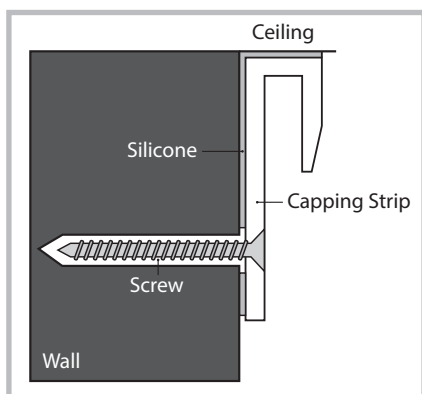

Installing the Joiner and Transition Profiles

Wall Cladding to flooring (skirting detail)

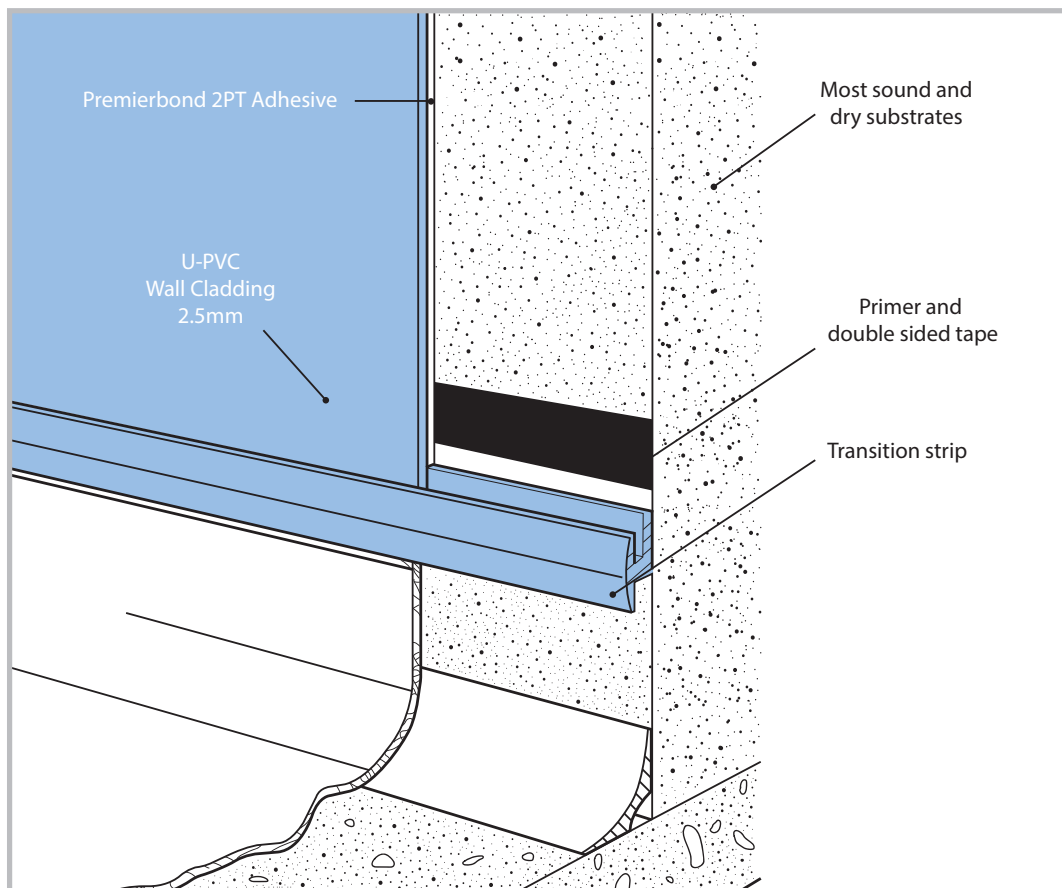

1 PART

2 PART

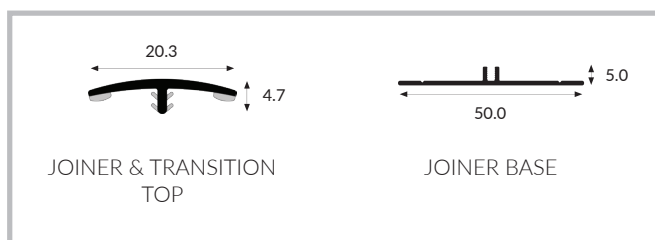
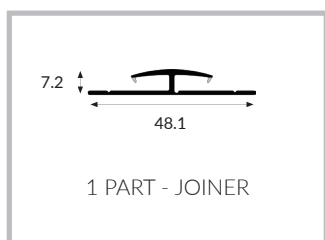

Step 1:

The Joiner base profile should be fitted onto the backing adhesive on the substrate (i.e. Premierbond 2PT).

Step 2:

Once the Joiner base profile is fitted, place the sheet onto the edge of the profile. Whilst holding the sheet in place, connect the Joiner and Transition base and the Joiner base profiles. This will now hold the sheet into place, creating a watertight finish.

Step 3:

To create a secure fixing, with moderate force, use a rubber mallet to tap the top of the profile.

Planning Layout

Planning the layout prior to installation is essential.

- This preparation helps minimise the number of profiles used in the system.
- Planning the layout evades the possibility of misalignment between the profile and the subsequent sheet.
- Before installing the sheets, plan out where the profiles will fall in the cladding operation.
- Ensure you have all of the correct profiles, equipment and adhesives prior to installation.

Sheet Preparation

- Carefully place the sheet onto the workbench, examine for damage prior to preparing the measurements. Once you are content with the quality of the sheet, on the protective film side, carefully mark the datum line using a pen. Be careful when marking the datum line, as too much force can cause damage to the surface of the sheet.
- Using the recommended safety equipment and tools, cut the sheet to size. Then remove the protective film approximately 50mm from the edge. The undercovered edges will allow space for the sheet to be fitted into the profiles. Make sure you do not fully remove the protective film until the installation process is fully complete.
- Test the sheet by holding it up against the substrate, ensuring you have 3mm expansion gap at all supports. This will allow you to check if the measurements were correct and that all components fit correctly.
- Once the sheet has been tested, carefully place the sheet, protective film down, onto the workbench. Clean off any contamination from the substrate i.e dust.

Adhesive Recommendations: Premierbond 2PT adhesive is recommended for all installations in wet areas such as bathrooms, kitchens and gymnasiums.

- Adhere to the adhesive packaging for directions of use.
- Apply the adhesive to the back of the sheet, using a 6mm notched trowel, smoothing outwards from the centre. Flat plastered walls can have 3mm thickness of adhesive.
- The working time of the adhesive is approximately 40 minutes with the initial cure being 20 minutes.
- Prepare the following sheets in the above process, for welding advice please see page 12.

Product Expansion

Our hygienic wall cladding should be installed within 3mm of inflexible supports such as door frames, ceilings and skirting. The 3mm gap will allow for expansion and contraction of the material. During installation, if measurements are inaccurate, the sheet may not be adjacent to the ceiling or corner line, this will create exposed edges. Accordingly, if there are any exposed edges of the sheet, we offer a comprehensive range of colour matched silicones. This range can be used to seal any exposed edges, creating a professional finish.

Thermoforming

We recommend the use of thermoformed internal / external corner detail when installing the sheets. This is achieved by heating the sheet on a thermoformer unit and manually forming the sheet to the desired angle.

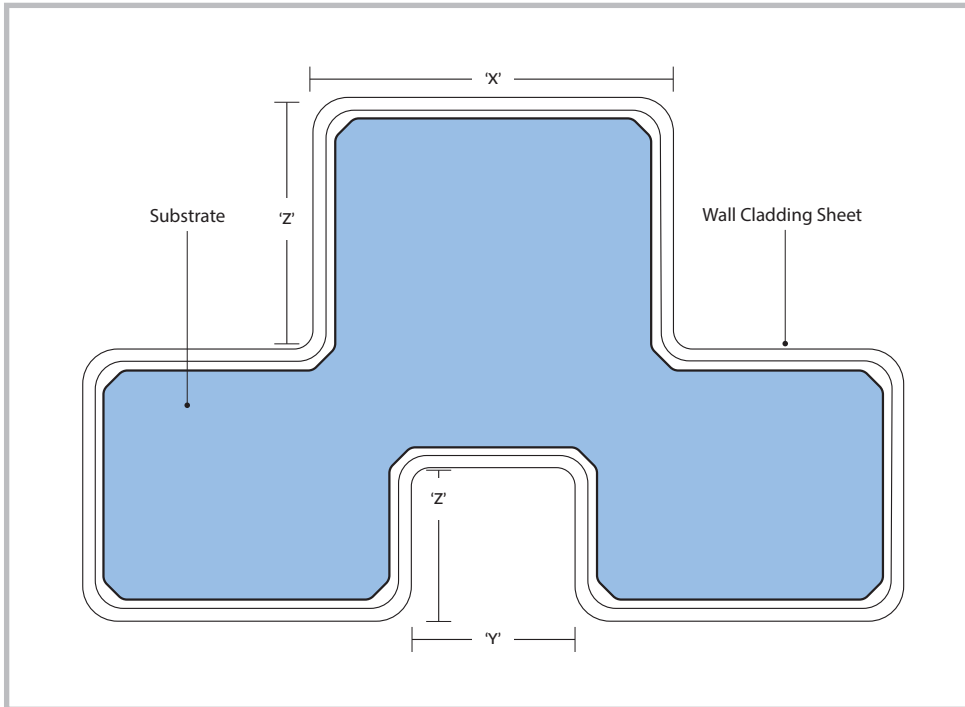

Please make sure that you follow the installation guidelines carefully to ensure the best results.

'X' - External to External corners = + 6mm

'Y' - Internal to Internal corners = - 6mm

'Z' - Internal to External / or External to Internal corners - Is the same measurement as substrate

All measurements to be marked on the protective film side of the sheet.

The above guidelines are for guidance purposes only.

Thermoforming Benefits

- Adaptive installation method suitable for all areas
- Low usage of tooling
- Visually pleasing appearance
- Wider design scope
- Lower tooling costs
- Accurately shaped corners
- Fully sealed hygienic finish

Heat Welding

- Ensure the weld rod and the joint gap are clean and free from contamination.
- The use of a welding gun is highly recommended to enhance overall efficiency.
- Heat welding is recommended at approximately the same room temperature at which the area will be used, this helps to prevent warping of the product.
- The use of heat will soften the weld rod and the sheet edge to fuse these materials together.

Heat Welding Installation

- As you place the sheets on the wall, allow 1.5mm gap between each sheet for the weld rod.
- Ensure the sheet and weld rod are clean and free from contamination.
- Set up the welding gun until the temperature/speed is adequate.
- A test patch is advised prior to beginning the installation to ensure the temperature/speed is suitable.
- Once the weld has cooled down it may be trimmed flush, please see below advise.

Trimming Off

- This process must be done carefully as the smooth wall cladding surface will highlight any imperfections.
- Pre-cutting must be done respectfully as taking too much off may result in an imperfect finish.
- It is advised that no more than half of the excess weld rod is pre-cut. This is to avoid the weld rod descending into the joint once cooled.
- Allow the weld rod to fully cool down before completing the final trimming.

Ceiling Installation

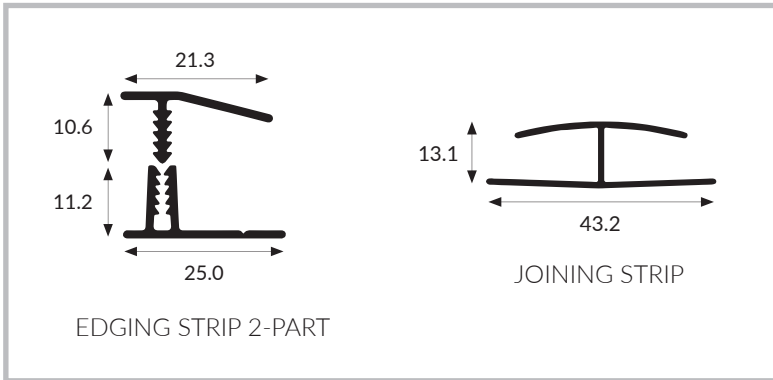

Step 1:

(Diagram 1)

Form a suitable method of placing the first ceiling plank edge into place and connecting the leading edge to the ceiling through the thin flange, which should be on the upper surface.

Step 2:

(Diagram 2)

Connect each corresponding plank into the proceeding one, inserting a joining strip profile between every ceiling plank.

If the overall ceiling area is larger than the planks, complete a whole area up to the length of the plank. Then apply a joining strip along the edge of the plank and continue the installation as per previous steps.

(Diagram 1)

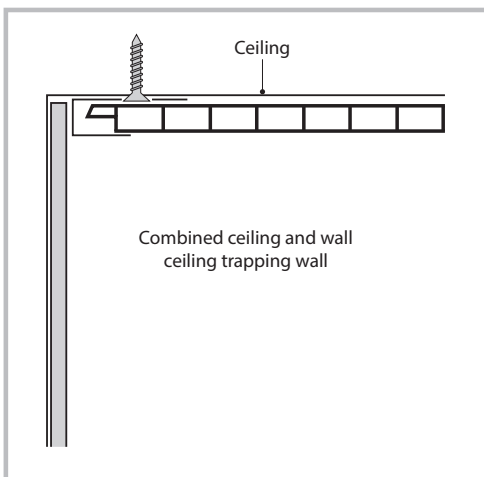

This method of installation uses a edging strip 2-part profile. Connect part one (backing strip) of the edging strip to the ceiling using a suitable silicone and fix with a screw through the long edge of the profile. It is recommended to use a larger amount of silicone against the connecting edge of the sheet to ensure a watertight installation. Place the ceiling plank into the correct position and clip in the part two facing strip into place.

(Diagram 2)

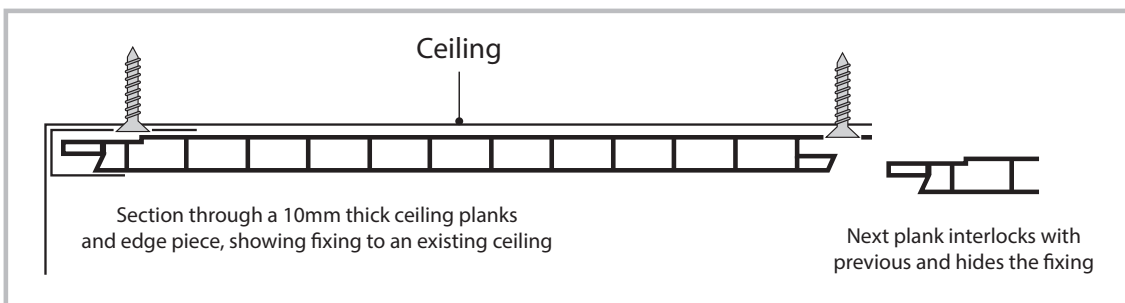

Hygienic Wall Cladding Cleaning Guide

Initial Cleaning Preparation

Once all sheets and profiles are installed, allow sufficient time for the adhesives/sealants to fully cure prior to cleaning. Begin by removing the protective film from sheets and profiles and clean all surfaces with an anti-static solution or anti-static cleaning wipes. This is required as the sheets may have static build up, therefore any dust in the atmosphere will adhere to the surface of the sheets.

Regular Cleaning

When cleaning the sheets, we recommend using a soft cloth with a mild soap/detergent. The temperature of the water or cleaning solution should not exceed 60°C. To reduce the build up of static, we recommend cleaning the sheets with an anti-static solution or anti-static cleaning wipes.

For stubborn stains, we recommend using an alkaline cleaner in combination with a soft cloth. Pressure cleaning with hot water may be used. However, to prevent damage, ensure that pressure nozzle is a minimum of 2 feet (600mm) away from the sheets surface.

Please be aware some cleaning products containing abrasives or solvents may adversely affect the sheets. A regular cleaning programme is recommended and may be developed to suit the usage and traffic of the area. For general use in hygienic environments, we recommend thoroughly cleaning the sheets at least once per week.